

Aantal Consoles volgens VDI 6036 - Nombre de Consoles selon VDI 6036
 Number of Brackets according to VDI 6036 - Anzahl der Konsolen nach VDI 6036

Betonnen Muur* - Paroi en Béton* - Concrete Wall* - Betonwand*			
H	300 - 400		500-950
VDI 6036	class 1-2	class 3	class 1-2-3
L 400	2	2	2
500	2	2	2
600	2	2	2
700	2	2	2
800	2	2	2
900	2	2	2
1000	2	2	2
1200	2	2	2
1400	2	3**	2
1600	2	3**	2
1800	3	3	3
2000	3	3	3
2200	3	4**	3
2400	3	4**	3
2600	3	4**	3
2800	3	4**	3
3000	3	4**	3

(*): Voor montage in andere wanden:
 - Mogelijk dienen andere bouten en pluggen gebruikt te worden.
 - Het aantal consoles om aan de benodigde klasse te voldoen kan veranderen.
 Contacteer ons voor meer informatie.

(*): Pour montage dans d'autres parois:
 - Il peut être nécessaire d'utiliser d'autres vis et chevilles.
 - Le nombre de consoles pour être conforme à la classe requise peut varier.
 (**): Console(s) supplémentaire(s) nécessaire(s) pour être conforme à la classe 3.
 Veuillez nous contacter pour plus d'informations.

(*): For mounting in other types of walls:
 - It may be necessary to use other screws and plugs.
 - The number of brackets may vary in order to fulfill class 3.
 (**): Additional bracket(s) required to fulfill class 3.
 Contact us for more information.

(*): andere Wandmateriale:
 - andere Schrauben und Dübel sind möglicherweise erforderlich.
 - die Anzahl der notwendigen Konsolen zur Erfüllung der Anforderungen der Klasse kann sich ändern.
 (**): zusätzliche Konsole(n) sich erforderlich zur Erfüllung der Anforderungen von Klasse 3. Wir stehen zur Verfügung für weitere Informationen.

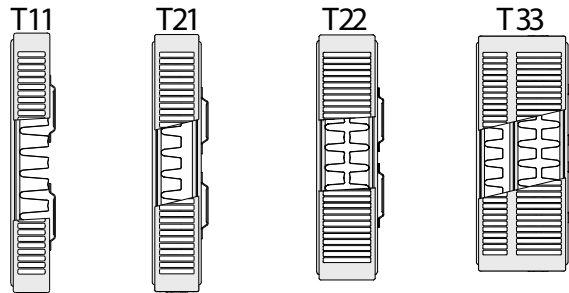

H	C	D
300	/	140
400	103	240
500	103	340
600	103	440
700	103	540
900	103	740

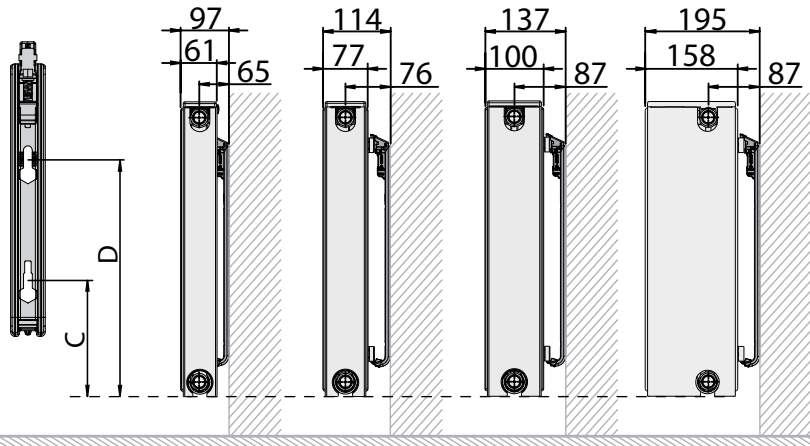

L	T11		T21 - T33	
	A	B	A	B
400	117	/	133	/
500 - 1600	150	/	133	/
1800 - 3000	150	17	133	0

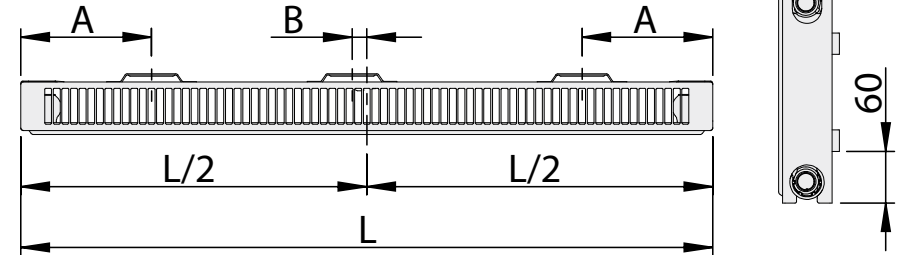

rechts - version droite
 right hand - Rechte Ausführung

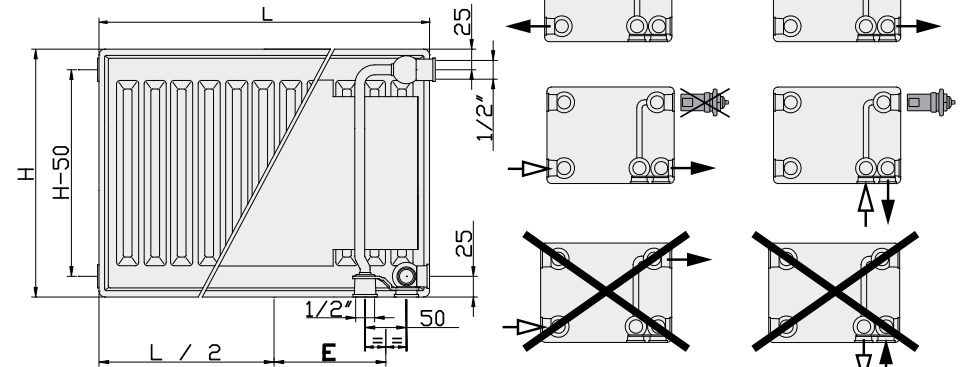

L	400	500	600	700	800	900	1000	1100	1200	1400	1600	1800	2000	2200	2400	2600	2800	3000
E	147	197	247	297	347	397	447	497	547	647	747	847	947	1047	1147	1247	1347	1447

links - version gauche
 left hand - Linke Ausführung

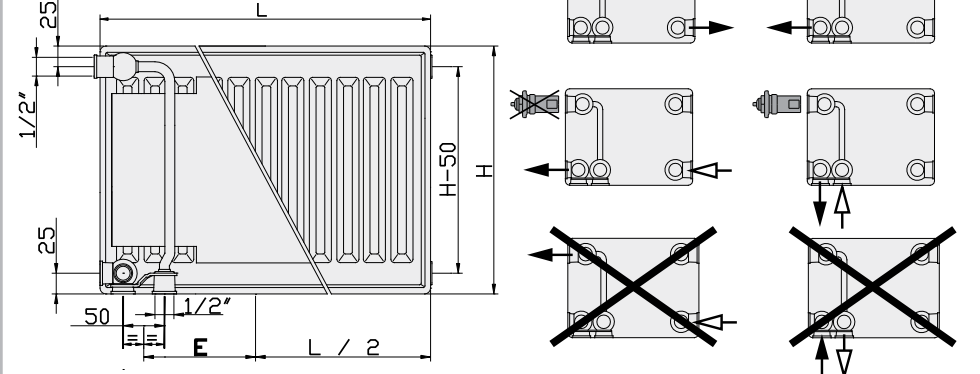

① *L >= 1800



4x (*6x)
2x (*3x)

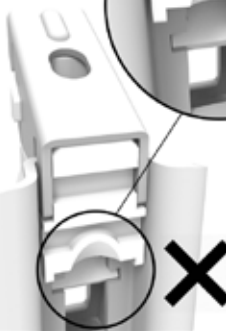
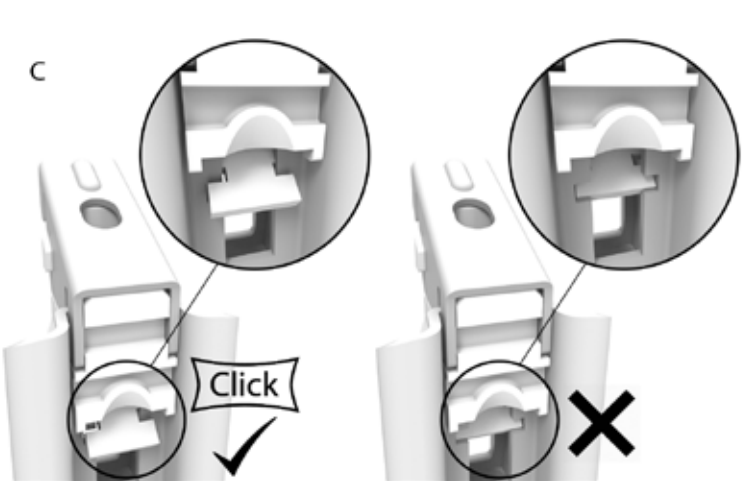
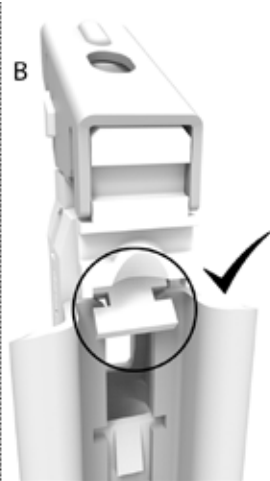

③

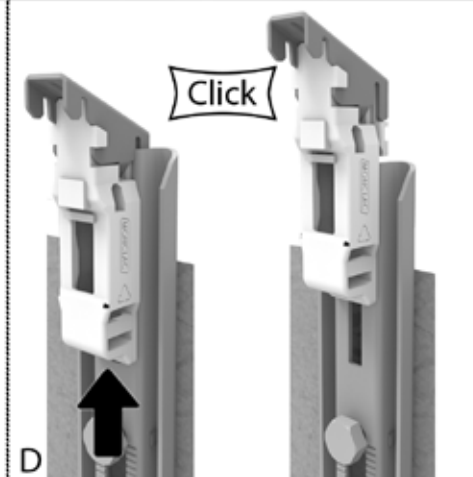
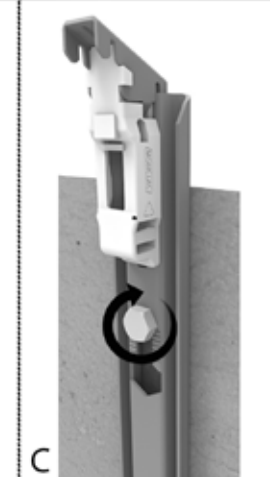
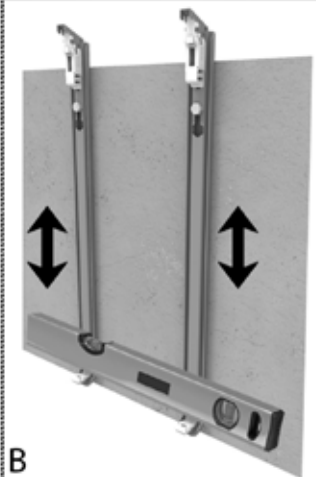
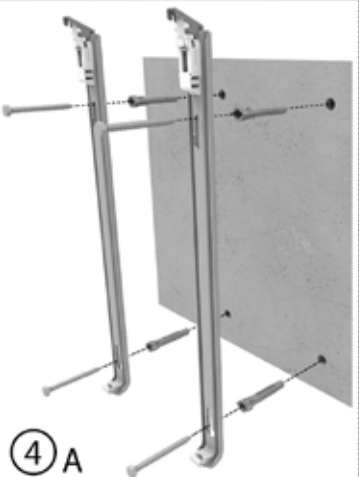
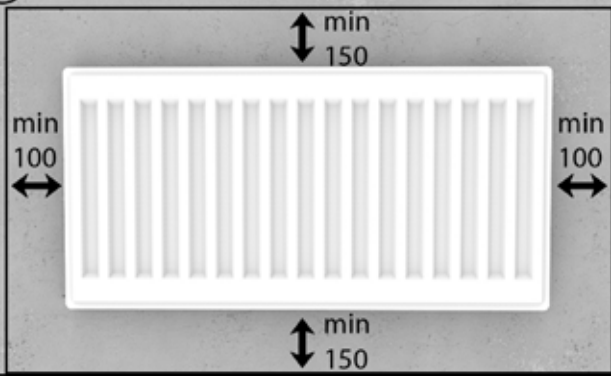

⑤



⑦

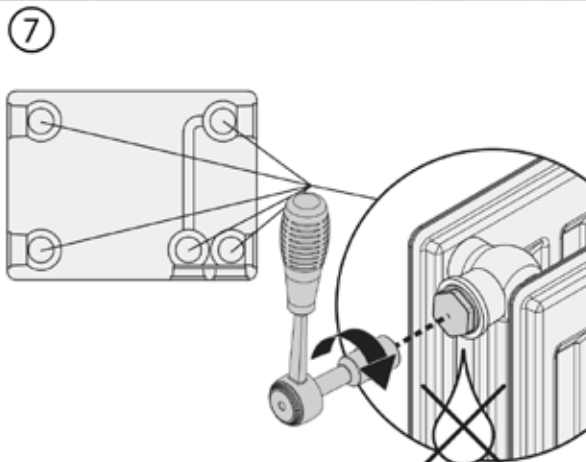

⑧

