

DISCOVER VERTEX STYLE

General information

VERTEX STYLE

In both traditional and trendy newly build and renovation projects large glazed sections and terrace windows are often used to optimise natural lighting and thus limiting the open wall space. With the Vertex Style Stelrad offers you the ideal solution. When combining the Vertex Style with Planar Style 8 and Compact Style models a light and spacious feeling is created throughout your home.

Product:	decorative vertical radiator with a centre connection and a stylised front
Finishing:	decorative stylised front and side panels
Also supplied:	wall brackets, ETA safety screws and plugs, screws, plugs, air vent, blind plugs and installation instructions
Connections:	4 x ½" female connection (centre connection included)
Lugs:	no lugs
Packaging:	Every radiator is sturdily packaged in high-quality cardboard and wrapped in plastic. The radiator's characteristics are shown on the label: type – height – length.
Warranty:	10 years, as long as the installation instructions have been followed and Stelrad's warranty conditions have been met.
Paint process:	All radiators are degreased, phosphated, cathodically primed and powder-coated in Stelrad white 9016 as standard.
Colours:	Stelrad white 9016 + 35 different Stelrad colours and about 200 RAL-colours are possible
Max. operating pressure:	10 bar (tested to 13 bar)
Max. operating temperature:	110 °C
Conformity:	in accordance with EN442
Quality assurance:	NF
Types:	11 20 21 22
Heights:	1.600 1.800 2.000 2.200 mm
Lengths:	300 400 500 600 700 mm
Depths:	49 79 79 102 mm



Type overview

Calculation factor
per meter
at 75/65/20°C
according to EN442

Characteristic equation:

$$\Phi = K_M \times \Delta T^n$$

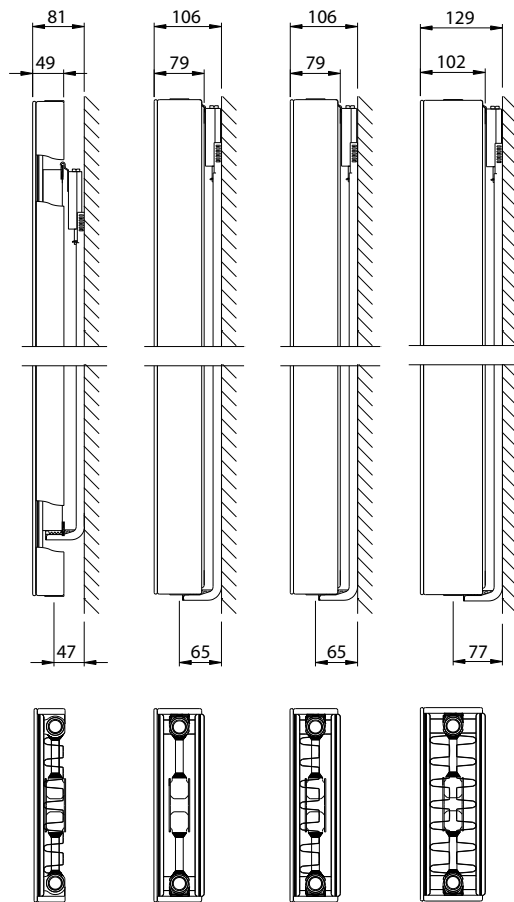

Height		Type 11	Type 20	Type 21	Type 22	Height
1600	W	1.959	2.310	2.808	3.420	1600
	kg	56,10	77,70	85,80	94,20	
	l	7,20	14,10	14,10	14,10	
	m ²	9,40	7,33	12,66	28,99	
	n	1,31	1,27	1,31	1,32	
1800	W	2.133	2.532	3.060	3.690	1800
	kg	63,00	86,70	96,00	105,30	
	l	8,10	16,20	15,90	15,90	
	m ²	9,86	8,25	13,58	29,90	
	n	1,30	1,27	1,30	1,33	
2000	W	2.298	2.748	3.270	3.960	2000
	kg	69,60	95,40	106,20	116,40	
	l	9,00	18,30	17,70	17,70	
	m ²	12,15	9,17	16,20	37,74	
	n	1,30	1,27	1,30	1,33	
2200	W	2.454	2.958	3.510	4.230	2200
	kg	75,60	105,60	116,40	126,60	
	l	9,90	20,10	20,10	20,10	
	m ²	12,61	10,09	17,11	38,66	
	n	1,29	1,27	1,30	1,33	

W=heat output per meter / kg=weight per meter / l=content per meter / m²=surface per meter / n=exponent
The manufacturer reserves the right to alter any of the specifications shown in this document without prior notice.

VERTEX STYLE

Heat outputs in Watt (EN442)



On the label:
VERTICAL DECO T11-22:

Art. 0276 18 22 04

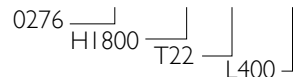

EN442 (W) 70/50/20°C

EN442 (W) 55/45/20°C

Stelrad BV/PL 1800-149/EC008

Height	1600				1800				2000				2200				Height
	Type	11	20	21	22	11	20	21	22	11	20	21	22	11	20	21	
300	439	522	629	764	479	572	686	824	516	620	734	883	552	668	788	943	300
	0276161103	0276162003	0276162103	0276162203	0276181103	0276182003	0276182103	0276182203	0276201103	0276202003	0276202103	0276202203	0276221104	0276222003	0276222103	0276222203	
400	586	696	839	1.018	638	763	915	1.098	688	827	979	1.178	736	891	1.051	1.257	400
	0276161104	0276162004	0276162104	0276162204	0276181104	0276182004	0276182104	0276182204	0276201104	0276202004	0276202104	0276202204	0276221104	0276222004	0276222104	0276222204	
500	732	870	1.049	1.273	797	953	1.144	1.373	860	1.034	1.223	1.472	920	1.113	1.314	1.572	500
	0276161105	0276162005	0276162105	0276162205	0276181105	0276182005	0276182105	0276182205	0276201105	0276202005	0276202105	0276202205	0276221105	0276222005	0276222105	0276222205	
600	878	1.044	1.259	1.528	957	1.144	1.372	1.647	1.032	1.242	1.468	1.767	1.103	1.336	1.577	1.886	600
	0276161106	0276162006	0276162106	0276162206	0276181106	0276182006	0276182106	0276182206	0276201106	0276202006	0276202106	0276202206	0276221106	0276222006	0276222106	0276222206	
700	1.025	1.218	1.468	1.782	1.117	1.334	1.601	1.922	1.205	1.449	1.712	2.061	1.287	1.559	1.839	2.200	700
	0276161107	0276162007	0276162107	0276162207	0276181107	0276182007	0276182107	0276182207	0276201107	0276202007	0276202107	0276202207	0276221107	0276222007	0276222107	0276222207	

Core assortment (Stelrad white 9016) available ex factory within 10 days.
Core assortment is subject to change, please refer to www.stelrad.eu for the latest information.
Delivery time depends on the model, please refer to your distributor.

CONNECTION POSSIBILITIES

View: front of radiator

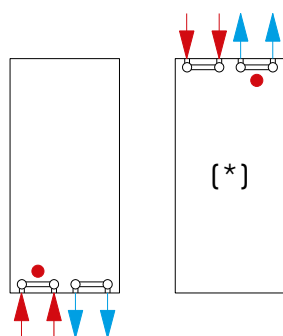

flow lock ●

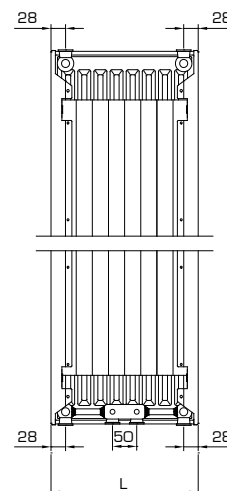
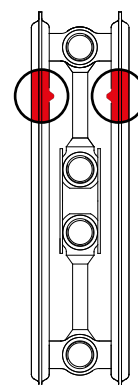

(*) With these connection options, both the supply and return must be vented.

Top connection allowed provided there is a temperature difference between flow and return of maximum 20°C.

WALL BRACKETS

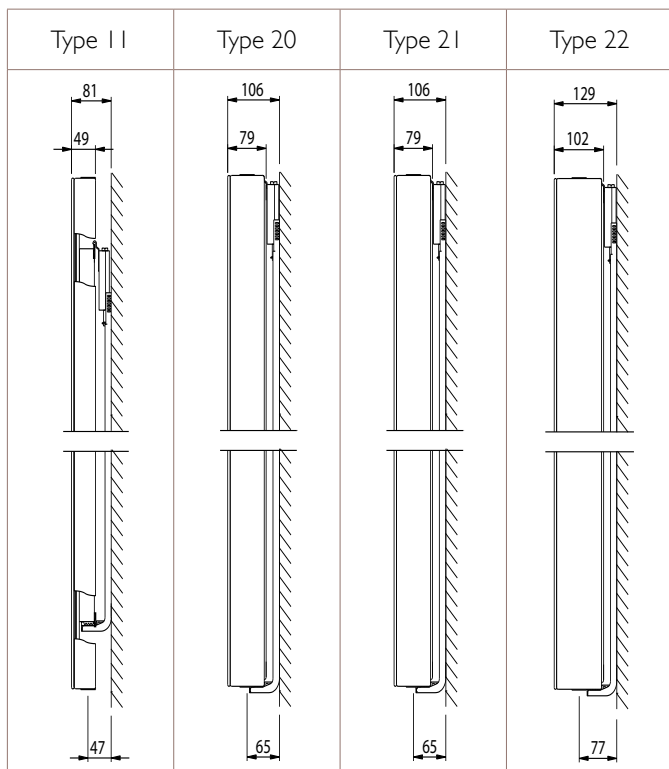

Nominal Height (mm)	Type 11			Types 20-22		
	H2	H3	H4	H2	H3	H4
1600	160	730	1300	70	740	1410
1800	160	830	1500	70	840	1610
2000	160	930	1700	70	940	1810
2200	160	1030	1900	70	1040	2010

Nominal Length (mm)	Type 11	Types 20-22
	B	B
L 300	50	60
L 400	80	110
L 500	130	160
L 600	180	210
L 700	230	260

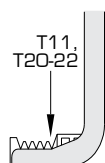
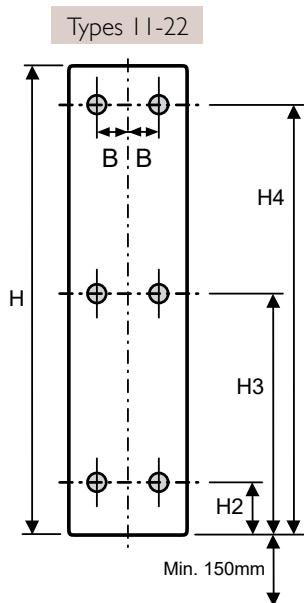

Always refer to the installation instructions and safety regulations before mounting a radiator!

An additional floor support for vertical radiators (types 20-22) is available for weak walls.

A professional inspection of the wall should always be conducted prior to mounting the radiator.

ATTENTION:

Always to be used in combination with the supplied wall brackets!

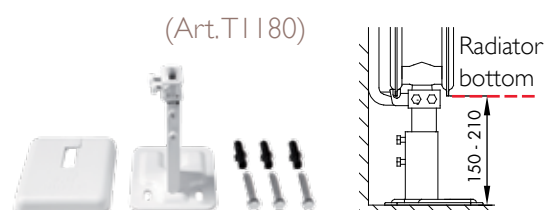

VALVED DESIGN CONNECTION FITTING

Specifications

- design cover
- design thermostatic head
- 2x 3/4" - 1/2" reduction
- 2x conical adapter
- Inlet on thermostatic head side
- valve with adjustable Kv (8 presettings)
- maximum operating temperature: 90°C
- maximum operating pressure: 6 bar
- maximum tightening torque: 35 Nm
- body in white high-quality plastic

The valve cannot be replaced.

For two-pipe systems, not suitable for one-pipe systems.



Design connection set straight piping with left handed valve

Art. N°.T2121 - white

Art. N°.T2122 - chrome

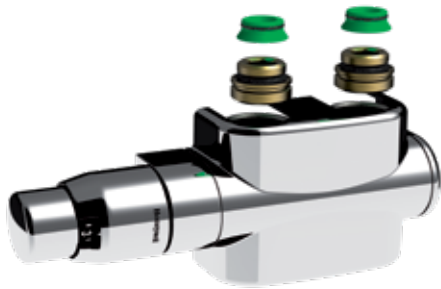

Design connection set angle piping with left handed valve

Art. N°.T2123 - white

Art. N°.T2124 - chrome



VALVED DESIGN CONNECTION FITTING

Adjustment of the valved connection fitting



Presetting	p-band xp 2,0 K	p-band xp 1,0 K
1	0,10	0,10
2	0,21	0,19
3	0,26	0,21
4	0,36	0,25
5	0,44	0,27
6	0,54	0,32
7	0,60	0,32
8	0,61	0,33

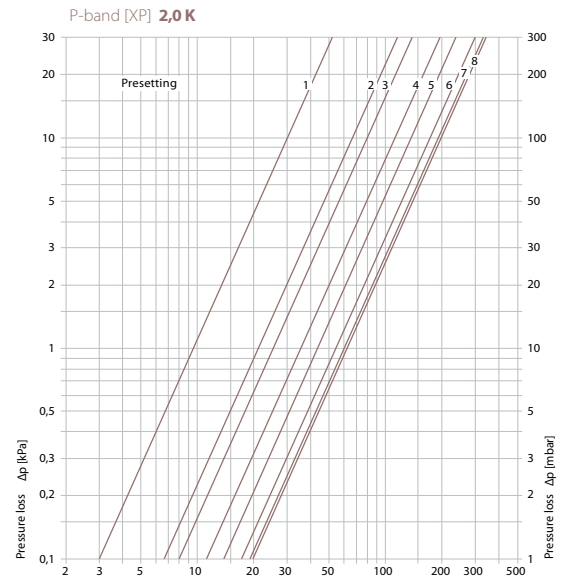
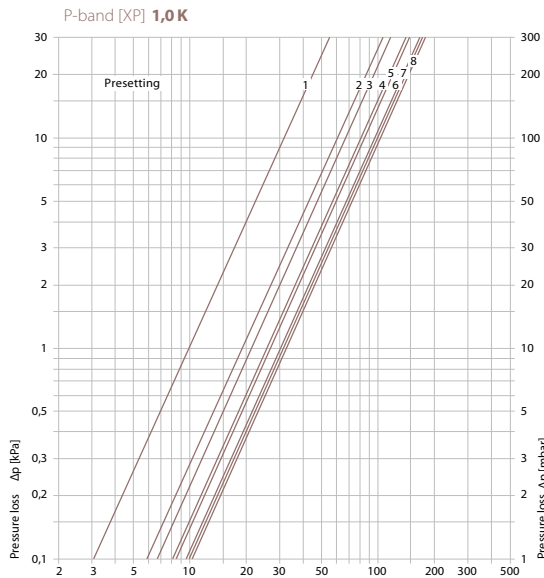

Lock function

The lock function can be used to lock the radiator without shutting down the heating system.

The valved design connection fitting closes the inlet and outlet by closing the closing screw and the thermostatic head.



Mounting dimensions

The supplied adapters enable the connection fitting to be fitted on the most commonly used connections: $\frac{3}{4}$ " external thread with flat sealing, $\frac{3}{4}$ " external thread Eurocone and $\frac{1}{2}$ " internal thread.

The mounting dimensions are also valid for the connection fittings without valve.

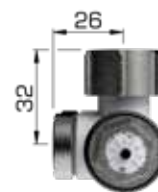

$\frac{3}{4}$ " external thread with flat sealing



$\frac{3}{4}$ " external thread Eurocone



$\frac{1}{2}$ " internal thread





Seasons

change,

and so

do we !

Austria • Belarus • Belgium • Cyprus • Czech Republic • Estonia • France • Germany • Greece • Iceland • Ireland • Lithuania
Luxemburg • Norway • Poland • Portugal • Slovenia • Spain • Sweden • The Netherlands • Tunisia • Ukraine • United Kingdom

THE NETHERLANDS

Caradon Stelrad B.V. | Kathagen 30 | 6361 HG Nuth

WWW.STELRAD.EU

